

Multi-lamp, low voltage halogen, recessed linear wall washer with nominal 5" (125mm) wide aperture, flanged trim and borosilicate supertex spread lens

TYPE: _____

JOB: _____

SPECIFIER: _____

SPECIFICATIONS

HOUSING - Extruded aluminum housing with overlap flange

SOCKET - Precision die-formed aluminum socket plate. G4/G6 ceramic socket with high temperature, teflon coated lead wires

MOUNTING - Recessed in architectural ceiling

LENS - Supertex borosilicate glass. Others available consult factory

ELECTRICAL - Fixture comes with terminal block for connection to power supply. Remote transformer if required should be sized for the run length and ordered separately

TRIM - Regress trim integral to housing

LAMP - MR-11 (FTB) narrow spot 20w max. supplied by others

FINISH - Powder paint on all surfaces in black and white as standard. Additional colors and RAL palette available. Consult factory for custom finishes

LABELS -UL, C-UL, Damp location

APPLICATIONS

Small profile wall washer used in ceiling heights up to 12 feet (4m) to smoothly wash vertical surfaces and minimize surface texture.

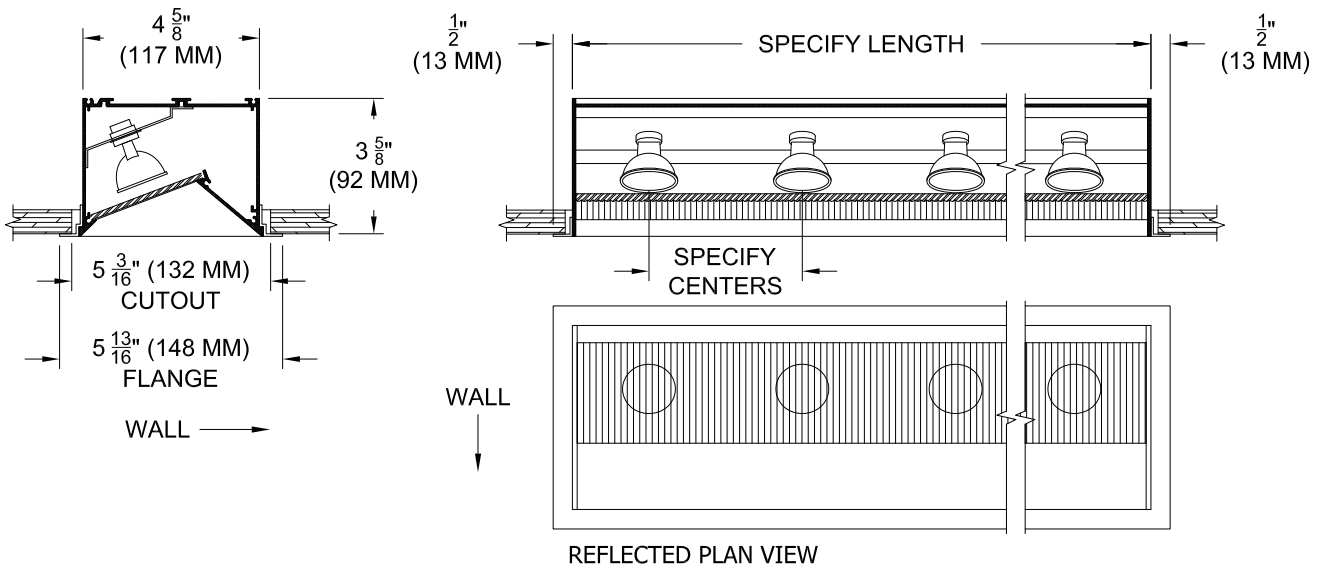

ORDERING INFORMATION

HOUSING	LENGTH	LAMP WATTAGE	LAMP SPACING	TRANSFORMER	TRIM FINISH	APERTURE LENS
613-MR11-FH						
Flanged Housing	Specify exact length	20 = MR11 20w 12v	4 = 4" 100mm 6 = 6" 150mm 8 = 8" 200mm or custom spacing	RX = Remote	WHT = White BLK = Black PXX = SLI Color XXXX = RAL # CST = Custom	82A = Frosted Supertex

This information is provided as a specification aid. A submittal will be prepared by the manufacturer for approval prior to fabricating this product.



SPECIALTY LIGHTING INDUSTRIES, INC.

NOTE: These specifications subject to change without notice.

www.specialtylightingindustries.com

1306 DORIS AVENUE, OCEAN, NJ 07712 USA 800.462.7812 732.517.0800 FAX 732.517.0971 © 07/11