

Single lamp, 25 degree adjustable in-ground uplight with nominal 5" square trim and optional glass diffuser. Uplighting for floors typically found in residential, commercial and retail applications. Suitable for new construction.

SPECIFICATIONS

HOUSING

- Precision die-formed heavy gauge aluminum with machined trim

MOUNTING

- Recessed in floor

ELECTRICAL

- Remote transformer required- sold separately

LAMP

- MR-16, supplied by others

SOCKET

- G4/G6 ceramic socket with high temperature, teflon coated lead wires

LENS

- Clear pyrex safety lens
- Optional borosilicate lenses available for aperture

TRIM

- CNC machined aluminum trim with bezel

FINISH

- Black powder paint housing
- Aperture trim available in black and white as standard
- Additional standard colors, RAL palette, custom finishes available

LABELS

-  , US tested to UL standards 1598, Damp location

JOB: _____
 SPECIFIER: _____
 TYPE: _____
 QUANTITY: _____
 SIGNATURE: _____

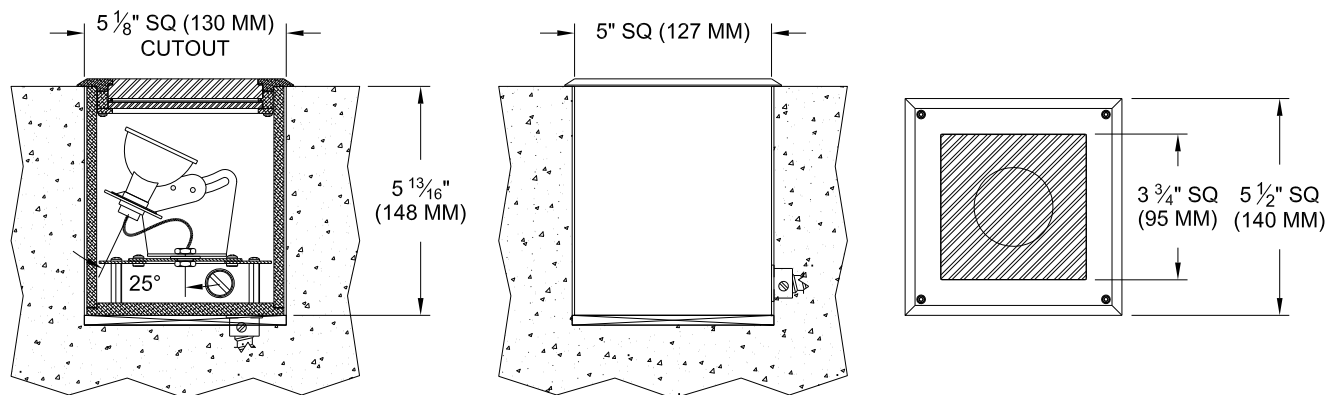

ORDERING INFORMATION

MODEL	TRANSFORMER	TRIM FINISH	OPTICAL LENS	APERTURE LENS
2005-MR16-IH				
In-Ground (5") Housing	RX =Remote / 120v / 277v	P14 = White BLK = Black PXX = SLI Color XXXX = RAL# CST = Custom	82A = Frosted Supertex 91A =Solite 92A = Supertex	CP = Clear Pyrex SP = Frosted Pyrex