

Twin lamp, low-voltage halogen recessed wall washer with nominal 4"x 8" rectangular 2 cell aperture and flangeless trim.

TYPE: _____

JOB: _____

SPECIFIER: _____

SPECIFICATIONS

HOUSING - Precision die-formed heavy gauge aluminum with extruded ceiling collar.

MOUNTING - Recessed in architectural ceiling.

ELECTRICAL - Integral dimmable electronic or toroidal magnetic transformer. 120v primary lead, (220v, 240v, 277v available), 11.75v secondary with overload protection. External thermoprotector.

LAMP - (2) MR-16 NFL, 50w max. supplied by others.

LABELS - UL, C-UL, Damp location

SOCKET - Precision die formed aluminum socket plate. G4/G6 ceramic socket with high temperature, teflon coated lead wires.

LENS - Frosted Supertex borosilicate spread lens, hinged for relamping.

TRIM - Flangeless, two piece die-cast aluminum pyramidal shield.

FINISH - Black powder paint housing. Aperture trim available in black and white as standard. Additional colors and RAL palette available. Consult factory for custom finishes.

APPLICATIONS

Wallwashing in medium to tall ceiling heights typically found in commercial and retail applications. Suitable for new or existing construction. Zero trim can be used with in solid surface ceilings such as wood, stone, metal panel or glass.

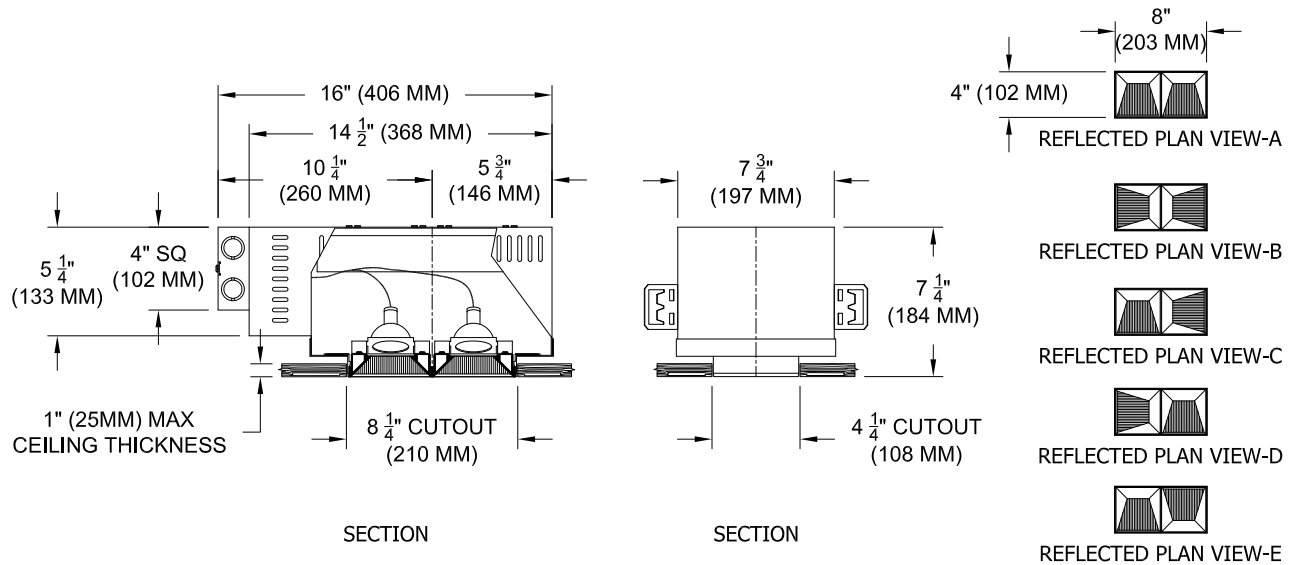

ORDERING INFORMATION

| HOUSING | TRIM | TRANSFORMER | FINISH | APERTURE LENS |
|--|---------------------|--|---|------------------------|
| 1240WW_-2MR16-UH | ZT | / | | 82A |
| Universal Housing WWA = Double WWB = Opposite WWC = Left WWD = Right WWE = Transverse | ZT = Flangless trim | TX = Magnetic 120V EX = Electronic 220V EX2 = 2 Circuit 277V Elect. | P14 = White BLK = Black PXX = SLI Color XXXX = RAL # CST = Custom | 82A = Frosted Supertex |



SPECIALTY LIGHTING INDUSTRIES, INC.

NOTE: These specifications subject to change without notice.

www.specialtylightingindustries.com

1306 DORIS AVENUE, OCEAN, NJ 07712 USA 800.462.7812 732.517.0800 FAX 732.517.0971 © 08/08