

Twin lamp, metal halide, recessed wall washer with nominal 4"x 9" rectilinear aperture.

TYPE: _____

JOB: _____

SPECIFIER: _____

SPECIFICATIONS

HOUSING - Precision die-formed heavy gauge aluminum.

MOUNTING - Recessed in architectural ceiling.

ELECTRICAL - Integral electronic ballasts. 120v primary lead, (220v, 240v, 277v available). External thermoprotector.

LAMP - (2) GE MR-16, 39w max. supplied by others.

LABELS - CSA-C,US, Damp location Wet with ST trim.

SOCKET - Precision die-formed aluminum socket plate. GX10 ceramic sockets with high temperature, silicone coated lead wires.

LENS - Supertex borosilicate spread lens, hinged for relamping. Optional filters available for lampholder.

TRIM - Flanged or flangeless, one piece die-cast aluminum pyramidal shield. ST trim fully sealed and gasketed.

FINISH - Black powder paint housing. Aperture trim stocked in black and white. Additional colors and RAL palette available. Consult factory for custom finishes. Wood trim available.

APPLICATIONS

Wallwashing in medium to tall ceiling heights typically found in commercial and retail applications. Suitable for new construction. Zero trim can be used with in solid surface ceilings such as wood, stone, metal panel or glass.

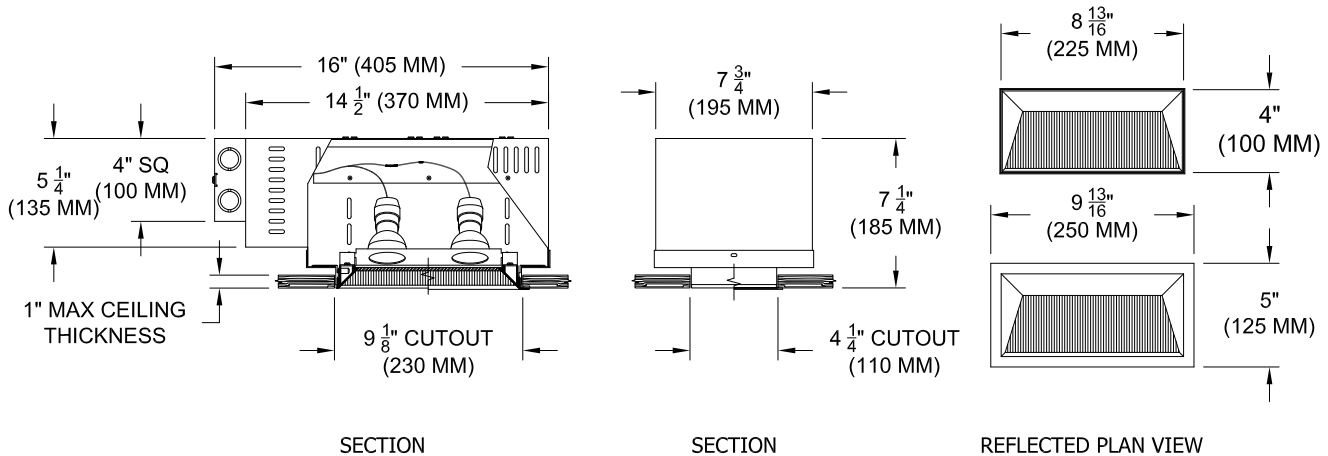

ORDERING INFORMATION

HOUSING	TRIM	BALLAST	LAMP LENS	TRIM FINISH	APERTURE LENS
1240-2MR16MH-UH		WATTS/VOLTS			82A
Universal Housing	FT = Flanged Trim ST = Shower Trim ZT = Zero Trim	20/120 39/120 20/220 39/220 20/240 39/240 20/277 39/277	98L - UV Filter	P14 = White PXX = SLI Color WXX = Wood XXXX = RAL # CST = Custom	82A = Frosted Supertex



SPECIALTY LIGHTING INDUSTRIES, INC.

NOTE: These specifications subject to change without notice.

www.specialtylightingindustries.com

1306 DORIS AVENUE, OCEAN, NJ 07712 USA 800.462.7812 732.517.0800 FAX 732.517.0971 © 10/10