

Dual lamp, low-voltage halogen recessed wall washer with nominal 4" x 9" (100mm x 225mm) rectilinear aperture.

TYPE: _____

JOB: _____

SPECIFIER: _____

SPECIFICATIONS

HOUSING - Precision die-formed heavy gauge aluminum with die-cast ceiling collar and adjustable mounting bracket.

MOUNTING - Recessed in architectural ceiling.

ELECTRICAL - Integral dimmable electronic or toroidal magnetic transformer. 120v primary lead, (220v, 240v, 277v available), 11.75v secondary with overload protection. External thermoprotector.

LAMP - (2) MR-16, NFL 50w max. supplied by others.

LABELS - CSA-C,US, Damp location, Wet with ST trim.

SOCKET - Precision die-formed aluminum socket plate. Nickel plated steel double contact bayonet base with stainless steel spring for optimum contact. High temperature silicone lead wires.

LENS - Supertex borosilicate spread lens, hinged for relamping. Optional filters available for lampholder.

TRIM - Flanged or flangeless, one piece die-cast aluminum pyramidal shield. ST trim fully sealed and gasketed.

FINISH - Black powder paint housing. Aperture trim available in black and white as standard. Solid wood, additional colors and RAL palette available. Consult factory for custom finishes.

APPLICATIONS

Wallwashing in medium to tall ceiling heights typically found in residential, commercial and retail applications. Suitable for new construction. Zero trim can be used with in solid surface ceilings such as wood, stone, metal panel or glass.

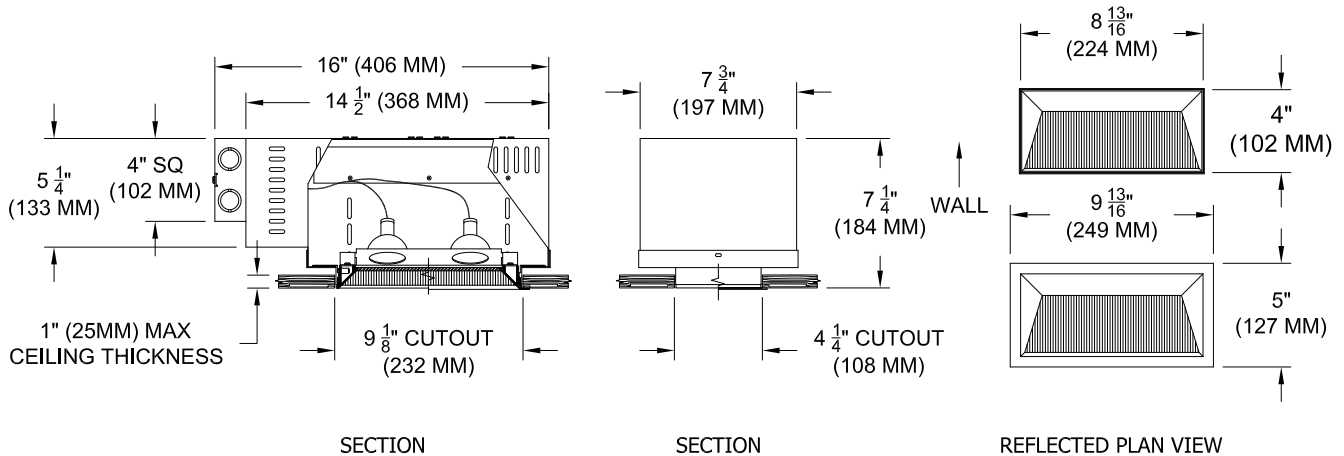

ORDERING INFORMATION

HOUSING	TRIM	TRANSFORMER		LAMP LENS	TRIM FINISH	APERTURE LENS
1240-2MR16-UH		/				82A
Universal Housing	FT = Flanged Trim ST = Shower Trim ZT = Zero Trim	RX = Remote TX = Magnetic	120 220 240 277	98L = UV Filter	P14 = White PXX = SLI Color WXX = Wood XXXX = RAL # CST = Custom	82A = Frosted Supertex



SPECIALTY LIGHTING INDUSTRIES, INC.

NOTE: These specifications subject to change without notice.

www.specialtylightingindustries.com

1306 DORIS AVENUE, OCEAN, NJ 07712 USA 800.462.7812 732.517.0800 FAX 732.517.0971 © 05/13