

Twin lamp, low-voltage halogen recessed wall washer with nominal 4"x 9" rectilinear aperture. Suitable for installation in ceilings up to 1" thick.

TYPE: _____

JOB: _____

SPECIFIER: _____

SPECIFICATIONS

HOUSING - Precision die-formed heavy gauge aluminum with extruded ceiling collar.

MOUNTING - Recessed in architectural ceiling.

ELECTRICAL - Integral dimmable electronic transformer. 120v primary lead, (220v, 240v, 277v available), 11.75v secondary with overload protection. External thermoprotector. Remote magnetic transformer available.

LAMP - (2) MR-16 NFL, 50w max. supplied by others.

LABELS - CSA-C,US, Damp location, Wet with ST trim.

SOCKET - Precision die formed aluminum socket plate. G4/G6 ceramic socket with high temperature, teflon coated lead wires.

LENS - Supertex borosilicate spread lens, hinged for relamping.

TRIM - Flanged or flangeless, one piece die-cast aluminum pyramidal shield. ST trim fully sealed and gasketed.

FINISH - Black powder paint housing. Aperture trim available in black and white as standard. Additional colors and RAL palette available. Consult factory for custom finishes.

APPLICATIONS

Wallwashing in medium to tall ceiling heights typically found in commercial and retail applications. Suitable for new construction. Zero trim can be used with in solid surface ceilings such as wood, stone, metal panel or glass.

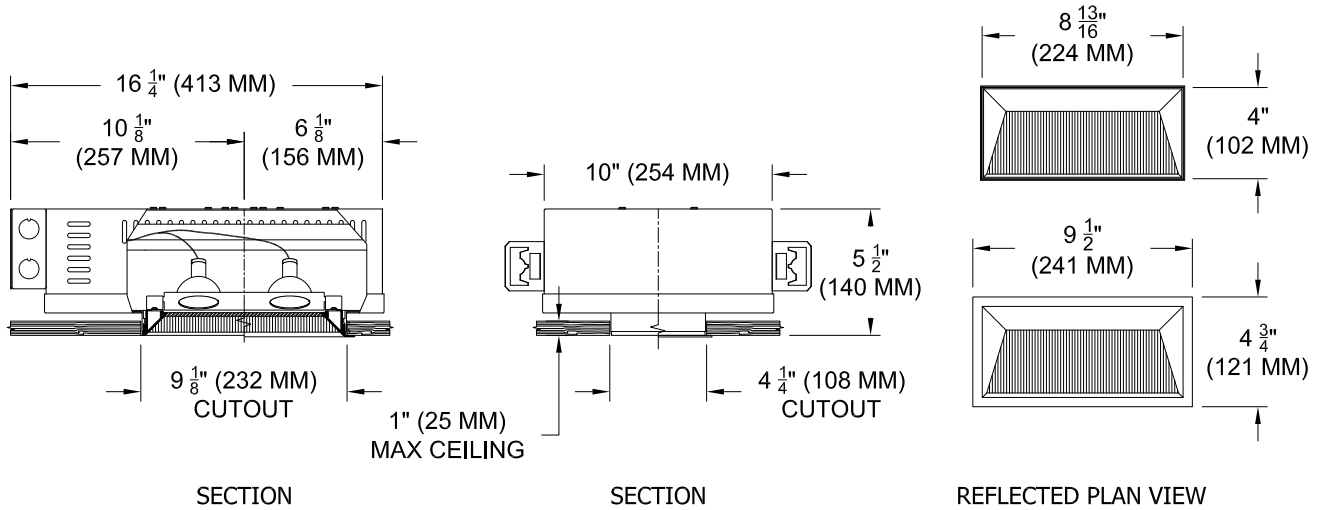

ORDERING INFORMATION

HOUSING	TRIM	TRANSFORMER	FINISH	APERTURE LENS
1240-2MR16-SUH		/		82A
Shallow Flangeless Housing	FT = Flanged Trim ST = Shower Trim ZT = Zero Trim	EX = Electronic 120 EX2 = 2 Cir Elec 220 RX = Remote 240 TX = Magnetic 277	P14 = Matte White BLK = Black PXX = SLI Color XXXX = RAL # CST = Custom	82A = Supertex



SPECIALTY LIGHTING INDUSTRIES, INC.

NOTE: These specifications subject to change without notice.

www.specialtylightingindustries.com

1306 DORIS AVENUE, OCEAN, NJ 07712 USA 800.462.7812 732.517.0800 FAX 732.517.0971 © 1/14