

Dual lamp, solid state light engine, recessed accent light with nominal 4"x 9" (100mm x 225mm) trim, rectilinear aperture and optional glass diffuser. Accent and downlighting in low to medium ceiling heights typically found in residential, commercial and retail applications. Suitable for new construction.

## SPECIFICATIONS

### HOUSING

- Precision die-formed heavy gauge aluminum with adjustable mounting bracket and die-cast ceiling collar

### MOUNTING

- Recessed in architectural ceiling

### ELECTRICAL

- Remote transformer required- sold separately
- Transformer should be sized for the run length
- External thermoprotector

### LAMP

- (2) MR-16, 50w max. supplied by others

### SOCKET

- Precision die-formed aluminum yoke with CNC machined lampholder assembly
- G4/G6 ceramic socket with high temperature, teflon coated lead wires

### LENS

- Clear pyrex safety lens.
- Optional borosilicate lenses available for lampholder and aperture

### TRIM

- Flanged or flangeless, 1 piece die-cast aluminum pyramidal shield
- ST trim fully sealed and gasketed

### FINISH

- Black powder paint housing
- Aperture trim available in black and white as standard
- Solid wood, additional colors, RAL palette, custom finishes

### LABELS

-  US, US tested to UL standards 1598, Damp location, Wet with ST trim,

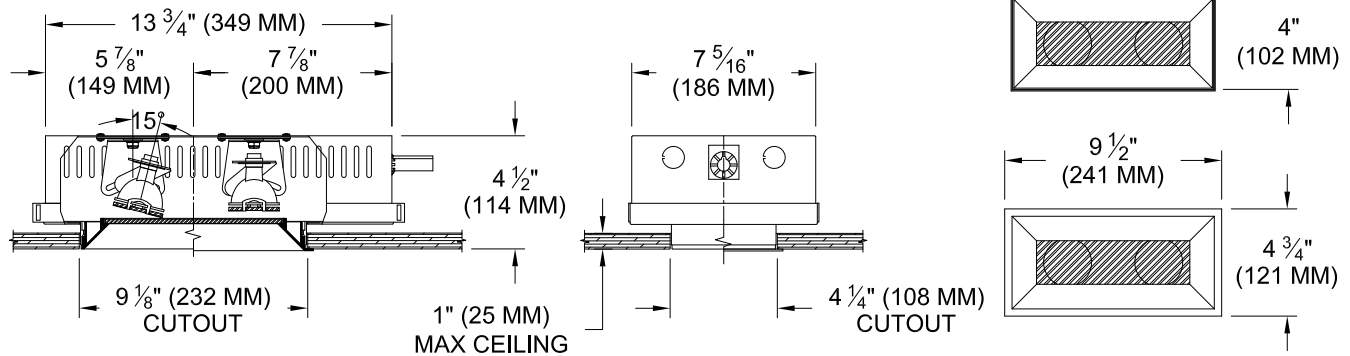
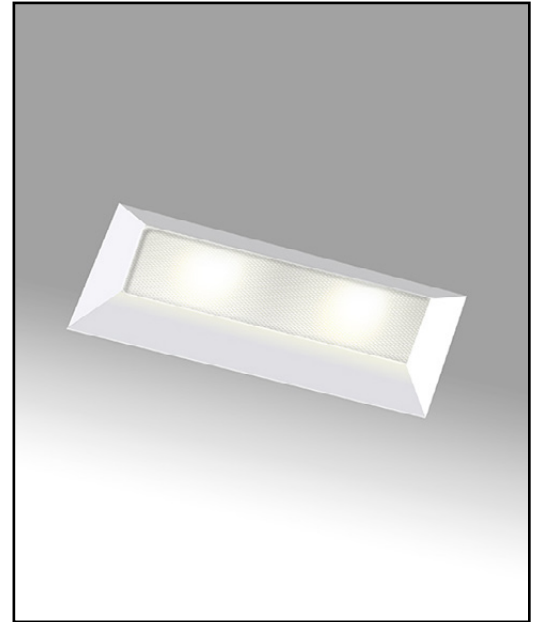

## ORDERING INFORMATION

MODEL	TRIM	TRANSFORMER	LAMP LENS	TRIM FINISH	APERTURE LENS
<b>1009-2MR16-TUH</b>					
Thin Universal Housing	<b>FT</b> =Flange Trim <b>PT</b> =Panel Trim** <b>ST</b> =Shower Trim* <b>ZT</b> =Zero Trim **WXX only *Aperture lens required	<b>RX</b> =Remote / 120v / 277v	<b>90L</b> = Clear <b>91L</b> = Solite <b>92L</b> = Supertex <b>93L</b> = Frosted <b>97L</b> = Black Hexcell <b>98L</b> =UV	<b>P14</b> = White <b>BLK</b> =Black <b>PXX</b> = SLI Color <b>WXX</b> = Wood <b>XXXX</b> = RAL # <b>CST</b> = Custom	<b>Blank</b> = None <b>91A</b> = Solite <b>92A</b> = Supertex <b>93A</b> = Frosted <b>95A</b> = Full Prismatic



Patent Pending.  
These specifications subject to change without notice.

[www.specialtylightingindustries.com](http://www.specialtylightingindustries.com)  
 1306 Doris Avenue, Ocean, NJ 07712 USA  
 800.462.7812 732.517.0800 FAX:732.517.0971