

## #815DL WOOD INSTALLATION

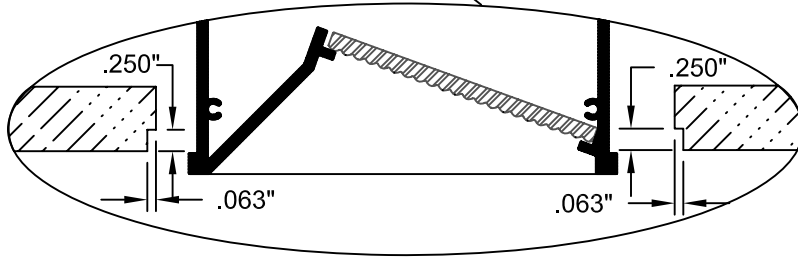

### MILL DETAIL

1/8" LARGER FOR  
FIXTURES LESS THAN 5'  
1/4" LARGER FOR  
FIXTURES LARGER THAN 5'

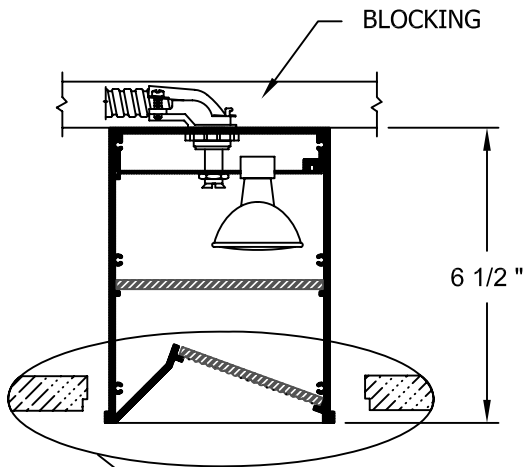

### OPENING

1. To flush mount the 815DL fixture, route the long sides of the aperture in accordance with the Mill Detail at left.
2. The length of the millwork aperture should be 1/8" - 1/4" longer than the fixture as shown on the Opening Detail at left to allow for expansion of the fixture.
3. Fixture may be mounted as a flanged unit proud of the millwork by omitting the routing of the long sides.
4. Provide blocking at least 6 1/2" above bottom of millwork to mount the fixture. The exact location of the mounting holes are shown on the submittal. A continuous length of blocking may be provided if rough out is being done prior to fixture order.
5. Provide greenfield between transformer location and fixture feed. Fixture comes with 10' whip of 10 gauge wire which must be pulled back through greenfield to the transformer. Longer lengths of supply whip can be provided if specified. One feed is provided for every 200-240 watts of connected load. The exact location and quantity of feed points is shown on the submittal drawing.
6. To install fixture; pull feed through greenfield and fasten connector to greenfield. Insert fixture through millwork opening. Screw through mounting holes into blocking until fixture is snug with ceiling.



SPECIALTY LIGHTING

INDUSTRIES, INC. © 2004

1306 DORIS AVENUE, OCEAN, NJ 07712 USA

800.462.7812 732.517.0800 FAX 732.517.0971

[www.specialtylightingindustries.com](http://www.specialtylightingindustries.com)